

THIS DRAWING IS UNPUBLISHED. RELEASED FOR PUBLICATION
 © COPYRIGHT BY TYCO ELECTRONICS CORPORATION. ALL RIGHTS RESERVED.

LOC	DIST	REVISIONS					
		P	LTR	DESCRIPTION	DATE	DWN	APVD
G	14		K1	REV PER ECR 06-001832	22APR06	JR	TM

AMP WIRE RANGE	Listed FILE E13288	LR7189 Certified
16-14 AWG SOLID OR STRANDED	16-14 AWG SOLID OR STRANDED	16-14 AWG SOLID OR STRANDED

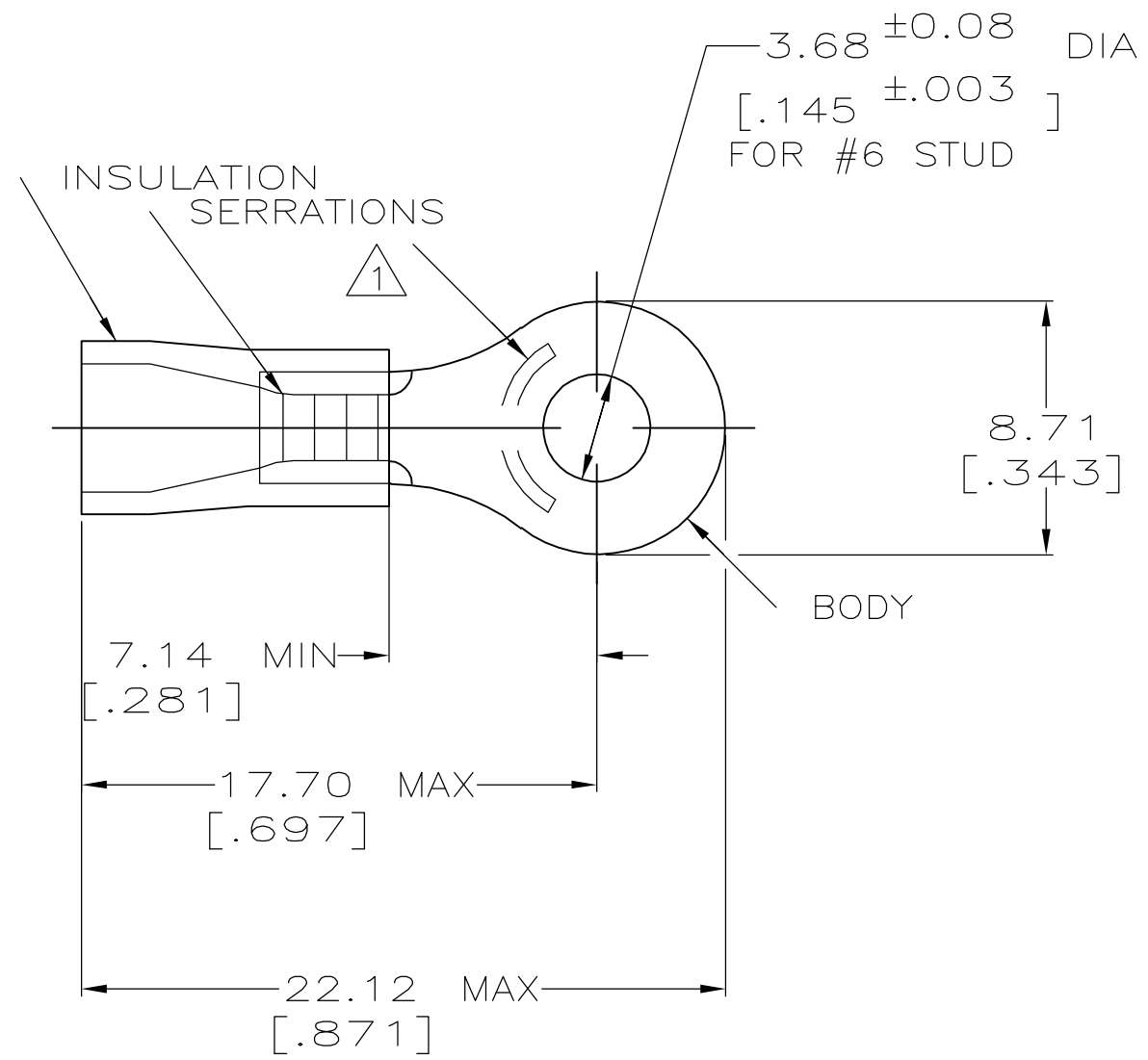

- ① STAMP AMP 16-14* APPROX AS SHOWN
- 2 WIRE INSULATION DIA: 3.00-4.90 [.118-.193]
- 3 TONGUE MATERIAL THK: 0.79^{±0.05} [.031^{±.002}]
- ④ MATERIAL: BODY - CU PER ASTM B152
SLEEVE - PVC, COLOR - BLUE

QTY	PACKAGE TYPE	PART NO.
5	LOOSE PC,BLS	8-34159-4
100	LOOSE PC,BOX	8-34159-1
5000	ON TAPE, REEL	2-34159-1
-	LOOSE PIECE	34159

AMP INCORPORATED
CUSTOMER SERVICE SYSTEMS

FOR ADDITIONAL PRODUCT INFORMATION OR COPIES OF DRAWINGS AND TECHNICAL DOCUMENTS
 PRODUCT INFORMATION CENTER
 1-800-522-6752

FOR APPLICATION TOOLING INFORMATION
 TOOLING ASSISTANCE CENTER
 1-800-722-1111

FOR ORDER ENTRY
 1-800-526-5142

MAX RECOMMENDED OPERATING TEMPERATURE:
 105°C [221° F]

VOLTAGE RATING:
 N/A

CIRCULAR MIL AREA:
 1.04-2.62mm² [2,050-5,180]
 SOLID OR STRANDED

THIS DRAWING IS A CONTROLLED DOCUMENT.

DIMENSIONS:
 MM [INCHES]

TOLERANCES UNLESS OTHERWISE SPECIFIED:

0 PLC	± -
1 PLC	± -
2 PLC	± 0.20 [.008]
3 PLC	± -
4 PLC	± -
ANGLES	± -

MATERIAL: TIN PER ASTM B545

DWN DK SCHRUM 08/06/92
 CHK RE HERSEY 11/10/92
 APVD M BARNABA 11/10/92

tyco
Electronics

Tyco Electronics Corporation
 Harrisburg, Pa 17105-3608

NAME: TERMINAL, RING TONGUE, PLASTI-GRIP
 WIRE SIZE: 16-14 AWG

PRODUCT SPEC: 108-1034
 APPLICATION SPEC: NOT AVAILABLE

SIZE: A3 CAGE CODE: 00779 DRAWING NO: C-34159 RESTRICTED TO: -

WEIGHT: -

CUSTOMER DRAWING SCALE: 4:1 SHEET: 1 OF 1 REV: K1